

OPUS B6 ECO

Operating Manual Hardware Description

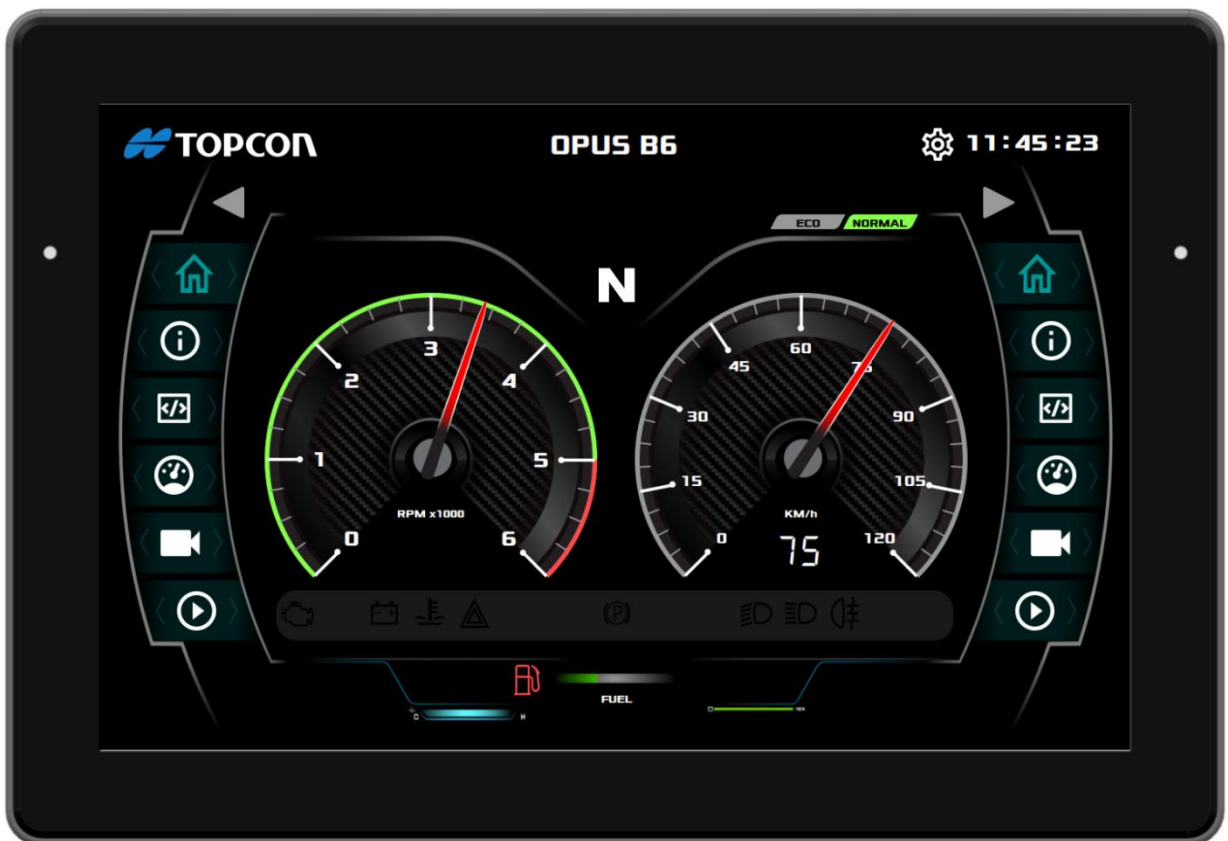

Versions

Example

OPUSB6EN1CANB000

OPUSB6

E

N

1

CAN

B

000

model

E=ECO; S= Standard

N= Neutral

1. Generation

CAN = Projektor/C++

CDS = CODESYS

ISO = ISO-UT Plugin

UTS = Horizon-UT

B=Basic, F= Full; A=Automotive Ethernet

customer specific identification

All product names cited in this operating manual are trademarks or registered trademarks of the respective companies.

Operating Manual OPUS B6 ECO

Order number: OPUSBA00B6

Topcon Electronics GmbH

Industriestraße 7, 65366 Geisenheim

+49 6722 / 6722 4026 - 888

Supplements or a special operator manual may be required for customer-specific devices.

Version 2.0, November 2024

All rights reserved, including translation.

No part of this operating manual may be reproduced, in any form, (print, photocopy, microfilm, or a different process), nor may it be processed, duplicated, or distributed using electronic systems, without written permission from Topcon Electronics GmbH, Geisenheim.

All content is subject to change without notice. All previous versions are rendered obsolete with publication of this manual.

All information contained herein is subject to correction, manufacturer is not liable for any errors in this material.

Errors and technical changes excepted.

Table of contents

1	Preliminary Notes.....	5
1.1	Used Instruction Types	5
2	Safety instructions, guarantee and liability	6
2.1	Common.....	6
2.2	Qualified Personnel	6
2.3	Power Supply	7
2.4	Interventions in the device.....	7
2.5	Safety Instructions for the OPUS B6.....	8
3	Intended Use.....	11
3.1	Example of Use	12
3.2	Device Description.....	13
3.2.1	OPUS B6 ECO	13
3.3	Features Overview for OPUS B6	16
3.4	Application Development.....	16
3.5	Development Kit.....	17
4	Getting Started	19
4.1	Check the delivered parts	19
4.2	Mounting.....	19
4.2.1	Standalone Mounting Instruction for OPUS B6.....	20
4.2.2	Connector Cover for OPUS B6 ECO	21
5	Electrical installation OPUS B6.....	22
5.1	Unused plugs	24
5.2	Power Supply	24
5.3	First steps	24
5.4	Cleaning/ service / maintenance	25
6	Technical Documentation.....	26
6.1	Dimension Drawings - OPUS B6 Eco.....	27

6.2	Specification	29
6.3	Declaration of Conformity	30

1 Preliminary Notes

This document is valid for the following OPUS B6 ECO version:

- OPUSB6E - "ECO"

This document is directed to the qualified personnel and contains all the important information to the correct use of the OPUS B6.



Please read this document before the first use and keep it during the operation.

In order to provide a better overview, this operating manual cannot present all details for handling the OPUS B6 in all conceivable application cases. Neither can all conceivable methods of setting up the device, operating the device, and servicing the device be discussed in this manual. In case more information or support is required please contact manufacturer technical support department.

1.1 Used Instruction Types

This operating manual contains instructions that must be complied with for your personal safety and in order to avoid damage to property.

The instructions are presented as follows listed by degree of hazard:

	Hazard! Very Important information Malfunction or Failure possible if non-compliance
	Caution! Severe bodily injury or property damage can occur if the respective precautionary measures are not taken
	Note Additional information about the product, the handling of the product or the respective part of the operating manual to which particular attention should be paid.

2 Safety instructions, guarantee and liability

2.1 Common

Read this operating manual before commissioning the OPUS B6. Keep this operating manual where it is accessible to all users at any time. Every person who is assigned to commission or operate the OPUS B6 must have read and understood the operating manual and the safety instructions in particular!

This operating manual contains instructions that must be complied with for your personal safety and in order to avoid damage to property. Failure to follow these safety instructions could result in fire, electric shock, or other injury or damage to OPUS B6 or other property.

2.2 Qualified Personnel

This operating manual is intended for technically qualified personnel, who have the appropriate skills in the area of measurement, control, and regulating technology.

Precise knowledge of all safety instructions and warnings contained in this operating manual, as well as problem-free technical implementation of these instructions and warnings are the prerequisites for hazard-free installation, commissioning, safe operation, and maintenance, of the operator panel. Consequently, it is strictly required that all measures be performed by qualified personnel.

Qualified personnel, in accordance with the safety and warning instructions contained in this operating manual are personnel, who

- are familiar with CANbus systems, related protocols and network designs that fulfill all legal requirements of the intended application, so that they are able to program the OPUS operator panel accordingly
- have gained knowledge of the programming related concepts by education or trainings. Using the Projektor Tool and Projektor Tool training by Topcon needs to be attended. Using CODESYS and CODESYS training needs to be attended, either held by Topcon or 3S.
- are familiar with the safety concepts of automation technology, either as project design personnel
- or operating personnel who have been instructed in how to handle the automation technology, and who are familiar with the section of this manual which deals with operation.
- or who, as commissioning, and service personnel have been trained to repair this type of automation technology, or who are authorized to commission, ground, and label electrical circuits and devices, or systems, in accordance with technical safety standards.

All persons who are involved in project planning, installation and operating the OPUS B6 must be familiar with automation technology safety concepts, and they must be qualified in accordance with the guidelines listed above.

Serious bodily injury and property damage can occur in the event of unqualified interventions in the device, or the system, or failure to heed the warning instructions specified in this operating manual.

Consequently, only personnel who are appropriately qualified may undertake interventions on this device, or on the associated system.

2.3 Power Supply

OPUS B6 is designed for 12 V and for 24 Volt battery systems. The operating voltage range is 8-36 VDC, overvoltage resistance 48V for 5 minutes, inverse-polarity protection up to -48 VDC for 5 minutes.

2.4 Interventions in the device

The OPUS B6 has been developed, manufactured, and tested in compliance with applicable standards. When the handling guidelines and safety-related instructions described here are complied with for project design, mounting, intended use, and maintenance, normally the product poses no hazards relative to property damage or to personal health. Nevertheless, the device can cause residual hazards if it is used or operated improperly by personnel who have not been trained.

In case of malfunctions or lacks please get in contact with the manufacturer. Any interventions in the device can cause serious interferences of the security for people and machines. They are not allowed and lead to disclaimer of liability and guarantee exclusion.



TOPCON is not liable for damage that occurs due to improper misuse of the delivered components, or through failure to heed the instructions in the operating manual, including the safety instructions.



TOPCON is not liable for damage that occurs due to unintended or intended changes of the TOPCON board support package or any other parts of the operating system.



TOPCON is not liable for damage that occurs due to improper programming and/or testing of the created application that runs on the OPUS operator panels.



TOPCON is not liable for damage or malfunctions occurs using pirated or illegal software on the OPUS operator panel.



TOPCON is not liable for injuries to third party licenses for the contents used on OPUS panel by the end customer.



Image retention (burn-in) on LCD displays is technically unavoidable. The customer must ensure that static images are avoided for extended periods of time (especially at higher ambient temperatures). This requires the use of a screensaver or other technical solution.

Moreover, we expressly declare that all obligations on the part of Topcon are exclusively derived from the respective purchase contract, in which the guarantee is conclusively stipulated.

2.5 Safety Instructions for the OPUS B6



Dangerous high-voltage

Never attempt to repair or modify OPUS B6 yourself. Disassembling OPUS B6 may cause damage that is not covered under the warranty and cause hazardous conditions by the high-voltage components inside of the unit.

OPUS B6 does not contain any user-serviceable parts. Service should only be provided by a Topcon Electronics GmbH.



Hazardous situations due to device failure

Do not use the OPUS B6 as the sole means of preventing hazardous conditions on vehicles, machines and equipment. Vehicles, machines and equipment must be constructed in such a manner that defective conditions associated with the OPUS B6 cannot cause a hazardous situation for operating personnel.

Ensure that incorrect inputs via the OPUS B6, its malfunction, or its failure cannot lead to major property damage, or to a hazard for operating personnel.



Missing safety devices if used improperly

Precautions for the safety of a system should not be rendered inoperable through the use of the OPUS B6.

Emergency-Stop devices must remain effective in all operating modes.



Unintentional operation

Operating states can be called due to unintentional operation of the OPUS B6 that are not appropriate for the situation.

OPUS B6 devices should be installed in such a manner that the possibility of unintentional operation is adequately excluded.



Undefined operating states

Undefined operating states can cause personal injury or property damage.

To prevent supply line and signal line interruptions from causing undefined or hazardous operating conditions, appropriate hardware and software safety precautions must be maintained.

Supply lines and signal lines must be installed in such a manner that noise (such as inductive or capacitive interference) cannot impair OPUS B6 function.

If a further usage of the OPUS B6 will cause danger, the device and if necessary the system needs to be switched off and be secured against unintended activation. This particularly applies:

- If the device shows visible signs of damage
- If the device is no longer functional
- If parts of the device are disconnected or loose
- if the connection lines show visible damage



Using Connectors and Ports:

Never force a connector into a port. Check for mechanical obstructions on the port. If the connector and port don't join with reasonable ease, they probably do not match. Make sure that the connector matches the port and that you have positioned the connector correctly in relation to the port.

3 Intended Use

The operator panel OPUS B6 is a programmable graphical display used to operate and monitor vehicles and working machines.

The communication with other system components, as for example decentralised I/O module, occurs over the CAN interfaces with the supported protocols: CANopen, J1939 and CANfreestyle (layer II).

For service purposes additional interfaces like RS232 and USB are available. Together with Embedded Linux operating system they form a universal platform for the communication with other CAN devices, networks or PCs.



The operator panel OPUS B6 is not admitted for security-relevant duties for personal protection purposes.



Vehicles, machines, and equipment surrounding the OPUS B6 must be combined in such a manner that the OPUS B6 will be warmed up equally from all sides. Increased warming of the OPUS from the back side may cause temporary fogging of the front glass or touch screen.

3.1 Example of Use

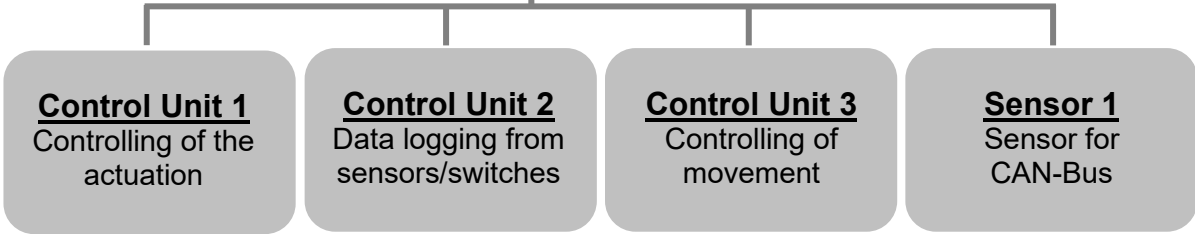
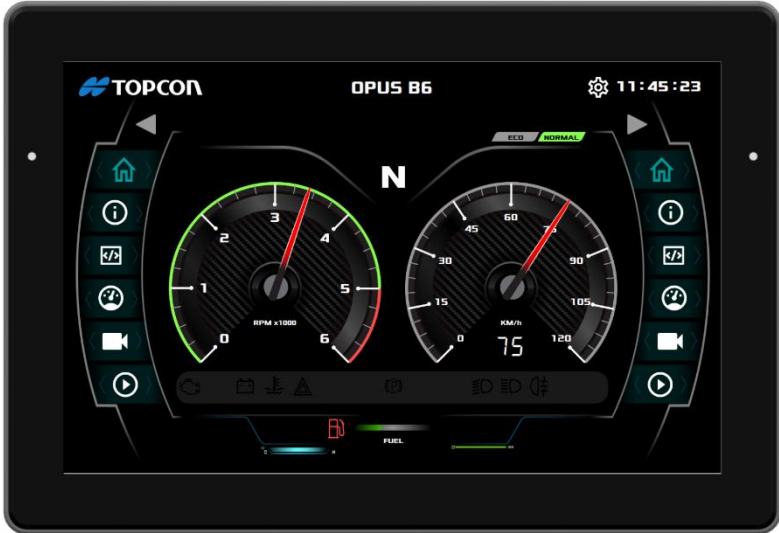

3.2 Device Description

3.2.1 OPUS B6 ECO



Fig. 3.1: Schematic diagram of the OPUS B6

Display:

10" (1280 x 800 px) TFT color graphic LCD display (optional) with capacitive touch.

Light Sensor:

The light sensor can be used for an automatic adaption of display-backlight to the ambient light intensity.

Multicolor Status LED:

There is one multicolor status LED available.

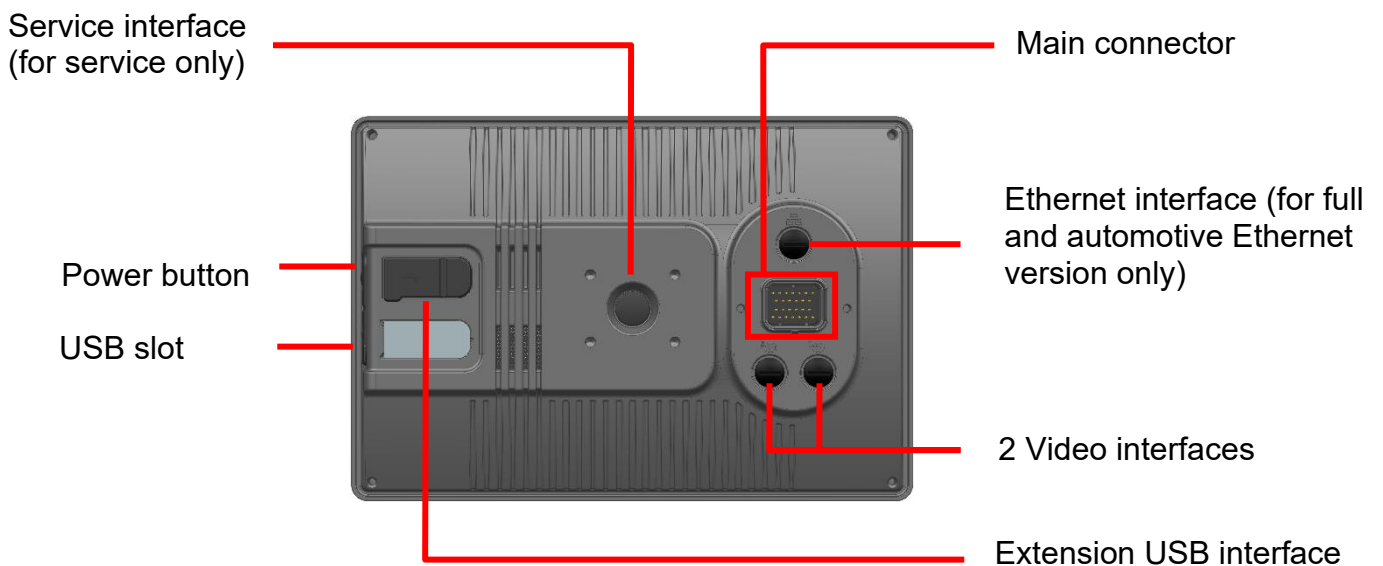

Fig. 3.4: Schematic diagram of OPUS B6 backside

Service interface:

On OPUS B6 there is a service interface available. This interface serves Topcon internal service use only.

Please do not remove the protection cap of service interface!

OPUS B6 may only be used with factory closed protection cap otherwise Topcon Electronics GmbH is no liable for any damage or malfunction.

Power button:

The OPUS B6 have a separate power button. This button may be programmable within the application running on OPUS B6 (see Projektor Tool Online Help, CODESYS Helpfile). Per default the display will be switched on press and switch off on long press (> 4 seconds).

Power-on/off behavior:

OPUS B6 can be switch on/off by the power supply directly.

As soon as the device is supplied with the necessary voltage via terminal 30 (battery plus), terminal 31 (battery GND) and terminal 15 (ignition), it will start to boot. In order to decrease boot time, the device supports power modes with which you can put the device in a sleep mode before it powers down.

When ignition voltage is removed, the device will switch to low-power-mode (see **C/C++ Developer Guide**). After a time, frame that can be configured (default time is 60 sec) the device will move one more step down to sleep-mode. After another 60 seconds (default time) the unit will fully switch off. As soon as terminal 15 is switched on again the unit will go back to on-mode in full operation.

Power Mode	current at 12 V DC	current at 27 V
On	≤ 1700 mA	≤ 850 mA
Low-power	Depending on configuration	Depending on configuration
Sleep	≤ 160 mA	≤ 85 mA
Off	≤ 5 mA	≤ 3 mA



Do not unplug clamp 30 from power supply on running unit. Power supply interruption on clamp 30 may cause data corruption and loss.

For more information, please refer to the **C/C++ Developer Guide**.

Extension USB interface (optional):

The OPUS B6 ECO offers extension interface in Full and Automotive Ethernet option only.

On OPUS B6 ECO Basic the option interface is stucked with protection rubber cover.

Please do not remove the protection rubber cover of extension interface!

OPUS B6 may only be used with factory closed protection rubber cover. Otherwise, Topcon Electronics GmbH is no liable for any damage or malfunction.

USB slot:

OPUS B6 offers USB slot on side and back to be used for software update and data transfer.

Main connector:

The following interfaces are available:

- Power supply and ignition input
- 4 x CAN-Interfaces according to ISO/DIS 11898
- RS232-Interface
- Wake Input
- Stereo Audio line out

3.3 Features Overview for OPUS B6

- Encapsulated aluminium housing to be mounted in landscape or portrait mode, standalone or in dash
- 10" TFT color display for automotive with resolution 1280 x 800 pixels
- Capacitive touch screen
- Powerful Freescale I.MX6® Dual/Quad 800/1000Mhz CPU
- 32bit processor with embedded Linux operating system (Linux kernel 4.14.0)
- Four CAN interfaces (ISO 11898) using CANopen® and SAE J1939 protocols. Layer II is supported
- Speaker
- RS232 interface for serial console
- High speed USB on the side and on back
- Wake Input
- Stereo Audio line out
- Industrial Ethernet / Automotive Ethernet
- Two Analog Video Input (PAL or NTSC only)
- Power button

The OPUS B6 is particularly characterized by its robust construction, and it has been developed especially for harsh use conditions in mobile work machines.

The Wake Input is connected to ground (GND) by default. The hardware input is permanently set to ground and cannot be changed. The signal can be inverted via software configuration, switching it to floating or 12 V. Please note that the signal must first be connected to ground in order to switch to 12 V or floating. It is therefore not possible to avoid the ground circuit directly.

3.4 Application Development

There are three possible ways to program the OPUS B6 and make it an integrated part of its application.

1. OPUS Projektor:

This powerful development environment provided by Topcon Electronics GmbH enables the quick and effective creation of an application for the OPUS B6 operator terminal. Use the Projektor to conveniently design the user interface on the computer, which can be easily displayed on the device. Additionally, this tool includes features to work with CANopen®, J1939 and CANfreestyle protocols for CAN communication.

For further information please refer to the ***OPUS Projektor Online Manual***.

With **ISO** devices, the OPUS B6 can be used as an ISO-VT slave in accordance with the ISO-11783 standard and DLG conformity. The necessary configuration is also done in the OPUS Projektor.

With **UTS/UTM/UTL** devices, the OPUS B6 can be used as an ISO-VT slave in accordance with the ISO-11783 standard and DLG conformity. The device is equipped with a Horizon application. Additionally, a PClient is running and custom pages can be added with the OPUS Projektor. The device is always sold as a UTS device. Upgrades to UTM (Task Controller) and UTL (Task Controller & Section Control) can be purchased.

2. CODESYS 3.x:

CODESYS is a programming tool and system developed by the German company 3S according to IEC 61131-3 standard. It supports different means of programming such as FUB or Structured Text. It can be used to program the OPUS B6 and CODESYS compatible ECUs. CODESYS includes the functionality to configure the CANopen®, J1939 and CAN Layer 2 protocol for communication over CAN bus.

For further information please refer to the **Codesys Help File**.

3. C-Programming:

OPUS B6 with its embedded Linux operating system can be fully programmed using C or C++ as programming language.

For further information and function-call list please refer to the **C/C++ Developer Guide**.



The operator panel OPUS B6 generation may only be handled due to the according operation manual.

3.5 Development Kit

For programming the graphical user interface of the OPUS B6 some different development kits are provided.

Topcon Toolchain with OPUS Projektor Order number: OPEP00B6CAN

Description	Order Number	Qty
Main connecting cable	OPKAB3CAN15	1
Ethernet cable		1
WE Toolchain download: - Projektor Tool - PClient - Documentation		1
Basic Projektor-Tool training at a Topcon facility		1
Projektor Tool license		2
12 month technical support		1

CODESYS 3.x

Order number: OPEP00B6CDS

Description	Order Number	Qty
Main connecting cable	OPKAB3CAN15	1
Ethernet cable		1
CODESYS software download: - Development Tool - Application - Target files - Documentation		1
Basic CODESYS training at a Topcon facility		1
12 month technical support		1

ISO-UT with OPUS Projektor

Order number: OPEP00B6ISO

Description	Order Number	Qty
Main connecting cable	OPKAB3CAN15	1
Ethernet cable		1
ISO-VT software download: - Projektor Tool - PClient - ISO-VT - Documentation		1
Basic Projektor-Tool training at a Topcon facility		1
Projektor Tool license		2
12 month technical support		1

Accessories not part of the Developer's kit:

Description	Order Number	Qty
Video Cable OPUS B6	OPKAA3VID010	1
Ethernet-to-USB adapter		1

4 Getting Started

4.1 Check the delivered parts

Please check whether all parts described in the scope of delivery have been delivered correctly. For question or reclamation please contact the support team of Topcon Electronics GmbH (opus-support@topcon.com).

4.2 Mounting

The unit is delivered without mounting accessories.

Depending on mounting type the following mounting accessories are available.

Standalone mounting connector cover (Order number OPUSB6EZBSA000)

Material	PC+ABS
Dimensions	99x62x102,5 mm
Operating Temperature	-30 ...+75 °C
Storage Temperature	-40 ...+85 °C
Max mounting torque	2,0 ± 0,2 Nm

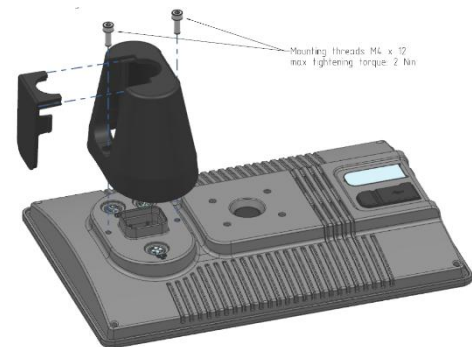

Both portrait and landscape positions are supported for mounting.

For mounting, please follow the instruction provided in the following dimensional drawing.

4.2.1 Standalone Mounting Instruction for OPUS B6

1. Thread connector cables through housing
2. Plug in main connector cable
3. Clip side cover plate into housing
4. Screw connector cover to device

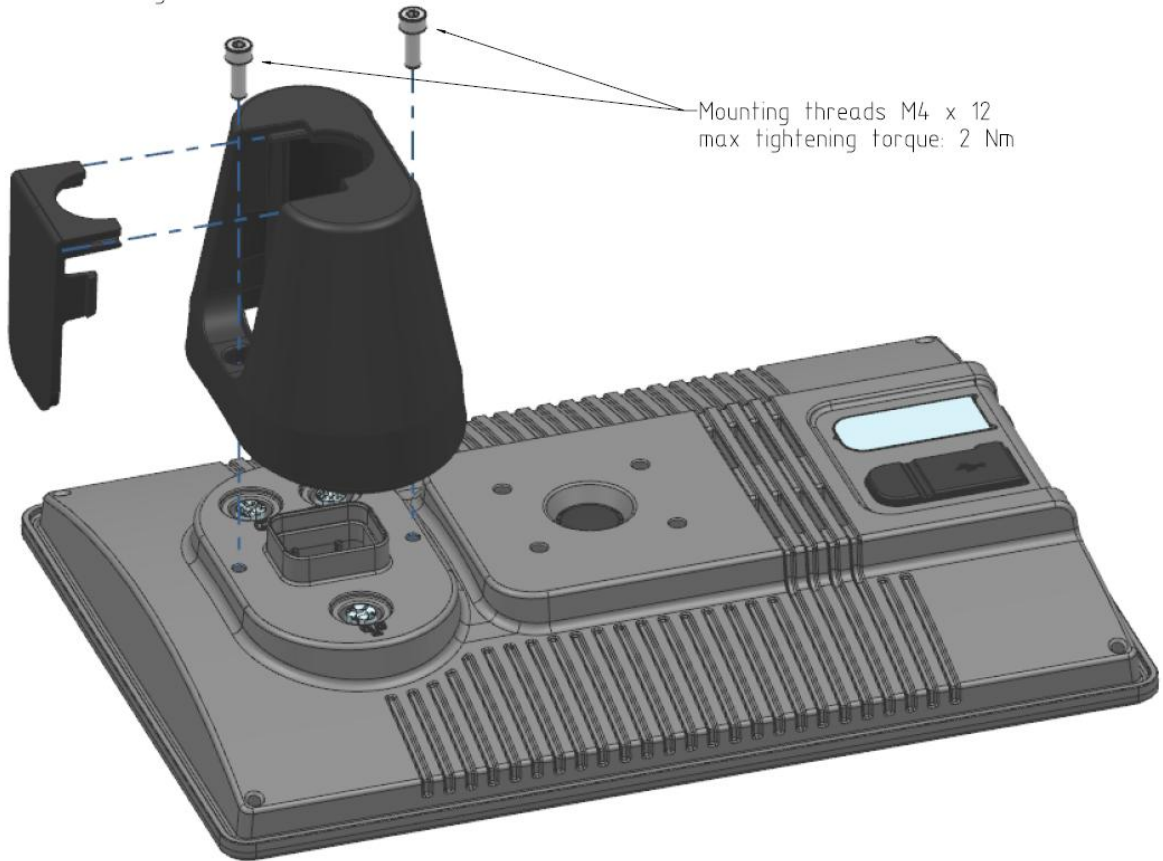

Parts List			
Pos.	Description	Order number	Supplier
1	OPUS B6 ECO	OPUSB6XX1XXX	Topcon Electronics
2	Dashboard	-	Customer
3	Connector Cover	OPUSB6EZBSA000	Topcon Electronics
4	M4 Screw* (DIN EN ISO 4762)	-	Customer

*Assignment of the screw length depends on dashboard thickness (thickness/length):

1mm – 3mm / M5 x 20

4mm – 6mm / M5 x 24

7mm – 10mm / M5 x 28



Attention!

Using too long screws can damage the unit!

Accepted mounting torque with mounting cover is 2,0 Nm

Please secure the screws with the thread locker medium strength (e.g. Loctite 243).

4.2.2 Connector Cover for OPUS B6 ECO

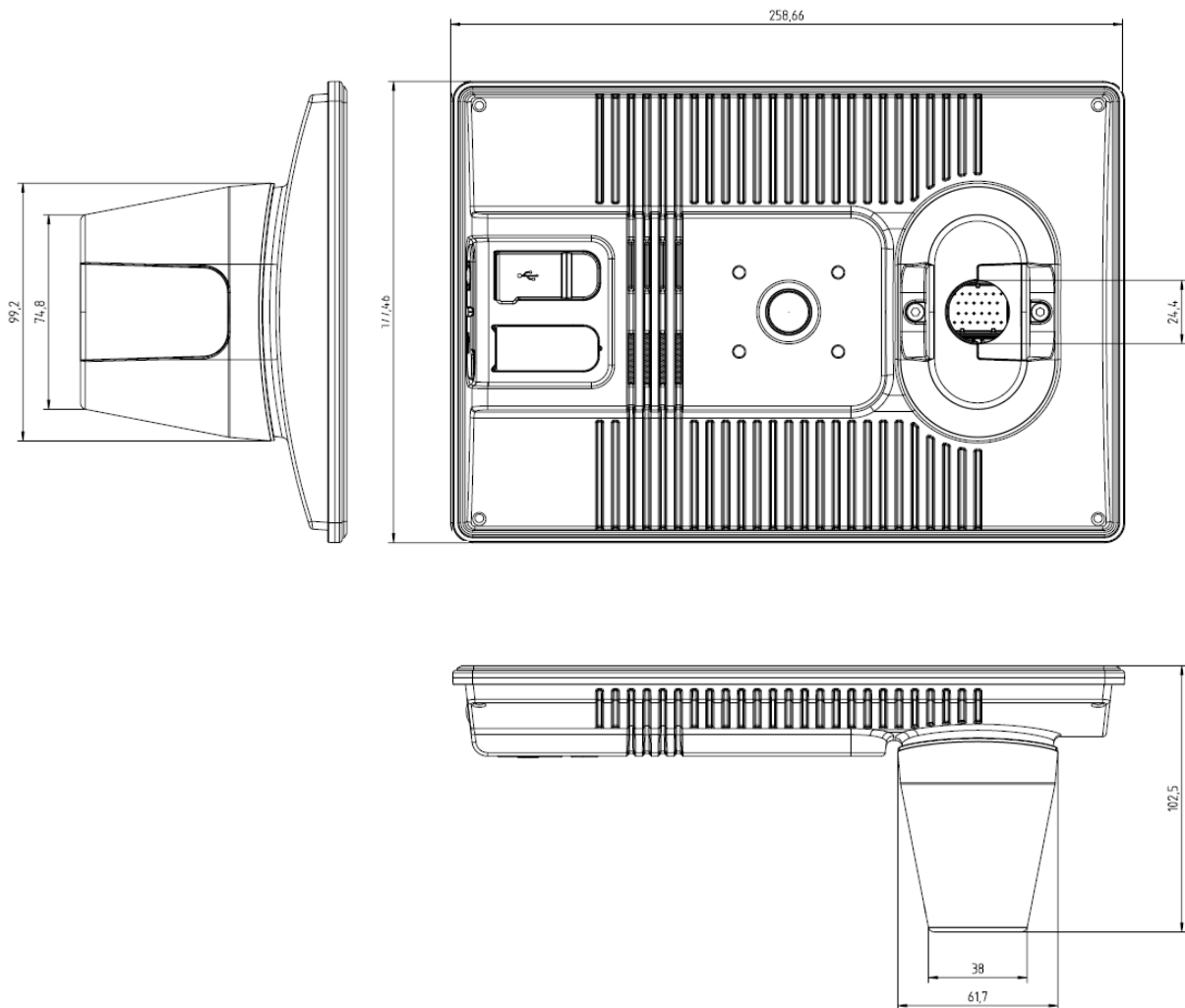

5 Electrical installation OPUS B6

Below you find the pin out diagram of the OPUS B6. The connectors (see fig. 3.3) are drawn as seen from the back side of the unit.

Please be aware that the existing pins and connectors depend on the hardware option you ordered.

Please note that the OPUS B6 only represents one part of the entire CAN network. Set-up and dimensioning of the network must be executed by specialized personnel, and the information in this regard cannot be a component of this operating manual.

Recommended torque for the M12 connectors is $0.8 \pm 0,2$ Nm.

Ethernet Connector, M12, female, 4 pins, d-coded

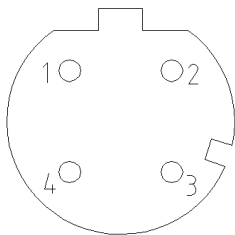

Main Connector

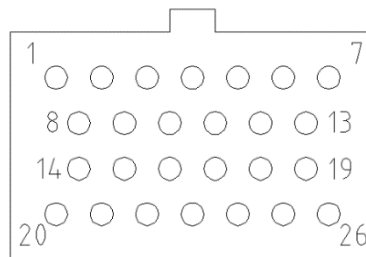

Video-Connector, M12, female, 5 pins, b-coded

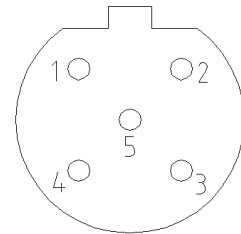

Ethernet connector pinout

Ethernet	Round Connector, 4 pins, M12, acc. To IEC 61076-2-101
1	TD+
2	RD+
3	TD-
4	RD-

Video connector pinout

Video	Round Connector, 5 pins, M12
1	VidSig+
2	Mirror
3	Camera+
4	Camera -
5	VidSig GND

Main connector pinout (in full option)

pin no.	assignment	description
1	VCC	supply voltage +; terminal 30
2	Ignition Input	ignition input; terminal 15
3	GND	supply voltage - ;terminal 31
4	Wake	Wake Input, "Doorswitch" (optional)
5	Audio Out_L	Audio line out, Stereo (optional)
6	Audio Out_R	Audio line out, Stereo (optional)
7	Audio GND	Audio line out, Ground (optional)
8	CAN1H	CAN bus 1 high signal
9	CAN1L	CAN bus 1 low signal
10	CAN2H	CAN bus 2 high signal
11	CAN2L	CAN bus 2 low signal
12	CAN3H	CAN bus 3 high signal
13	CAN3L	CAN bus 3 low signal
14	CAN4H	CAN bus 4 high signal
15	CAN4L	CAN bus 4 low signal
16	RS232: RxD	RS232: RxD
17	RS232: TxD	RS232: TxD
18	RS232: GND	RS232: GND
19	CAN2R	120Ω Termination CAN2
20	CAN1R	120Ω Termination CAN1
21	CAN4R	120Ω Termination CAN4
22	n.c.	
23	SERV_EN	service enable; to be connected while power-on for updating
24	n.c.	
25	n.c.	
26	CAN3R	120Ω Termination CAN3

To use the CAN termination CAN-H and CAN-R should be shorted on customer hardness.

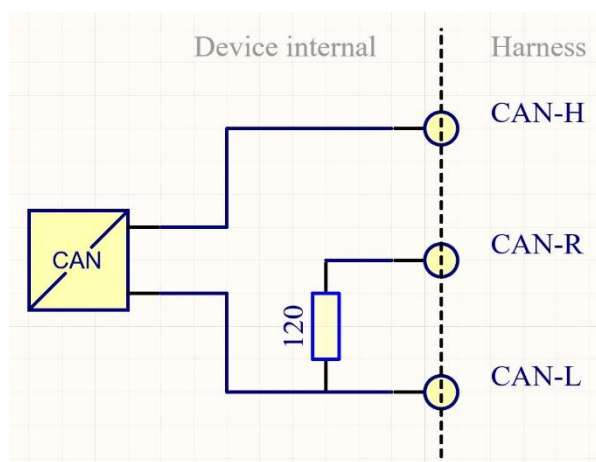

Please observe the following guidelines for set-up:

- Power supply lines should only be passed in pairs as close together as possible.
- Sensitive signal lines should be shielded to achieve highest possible damping, and under this shielding they should be still passed twisted.
- Metal plug connections should be used for shielded lines.
- Cable bundles should be distributed in accordance with their purpose (e.g. HF, LG, and power supply); the groups thus formed should not be routed in parallel to the extent possible, and they should be routed with clearance.

The OPUS B6 relies on a connection to an ECU that controls the functions and features of the target vehicle/machine.



The ECU must be the component in charge of all safety related functions.

Please keep all the connectors separated. All connection should be done on the shortest distance to the unit.



Wrong connection may cause damage of the unit.

5.1 Unused plugs



Penetrating humidity by unused and unprotected plugs may cause damage of the unit. Please protect unused plugs with the special blind inserts that have been supplied with the units.

5.2 Power Supply

The unit may be used with the 12 V and for 24 Volt battery systems, operating voltage range of 8-36 VDC. The overvoltage resistance is about 48V for 2 minutes. Inverse-polarity protection is up to -48 V DC.

5.3 First steps

Plug in the main connector into the OPUS B6. Then connect the clamps 15 and 30 for the plus voltage, as well as clamps for GND for the ground. Switch on the Power supply.

On start the boot-logo image will be displayed on the screen. This may be exchanged with the customer specific image (please refer to **C/C++ Developer Guide** for more information).

The boot up takes about 8 seconds and will then call the application according to the start scripts on the unit (start scripts for Projektor Tool and CODESYS application already installed by delivery).

The application displays the information of the required application software version. CODESYS and Projektor Toll applications also contains a simple function test. Each newly downloaded application will replace the old one automatically.

5.4 Cleaning/ service / maintenance

Cleaning agents which have an abrasive or dissolving effect on the coated glass pane, the foil of the touch screen or the plastic of the encoder or the housing should not be used to clean OPUS B6 operator panels. Only use soft clothes with a little soap and water or mild dish washing liquid.

The OPUS B6 does not have any parts that require service by the user. Repairs can only be performed by Topcon Electronics GmbH.

6 Technical Documentation

The OPUS B6 is currently available in one housing version.

OPUS B6 ECO:



6.1 Dimension Drawings - OPUS B6 Eco

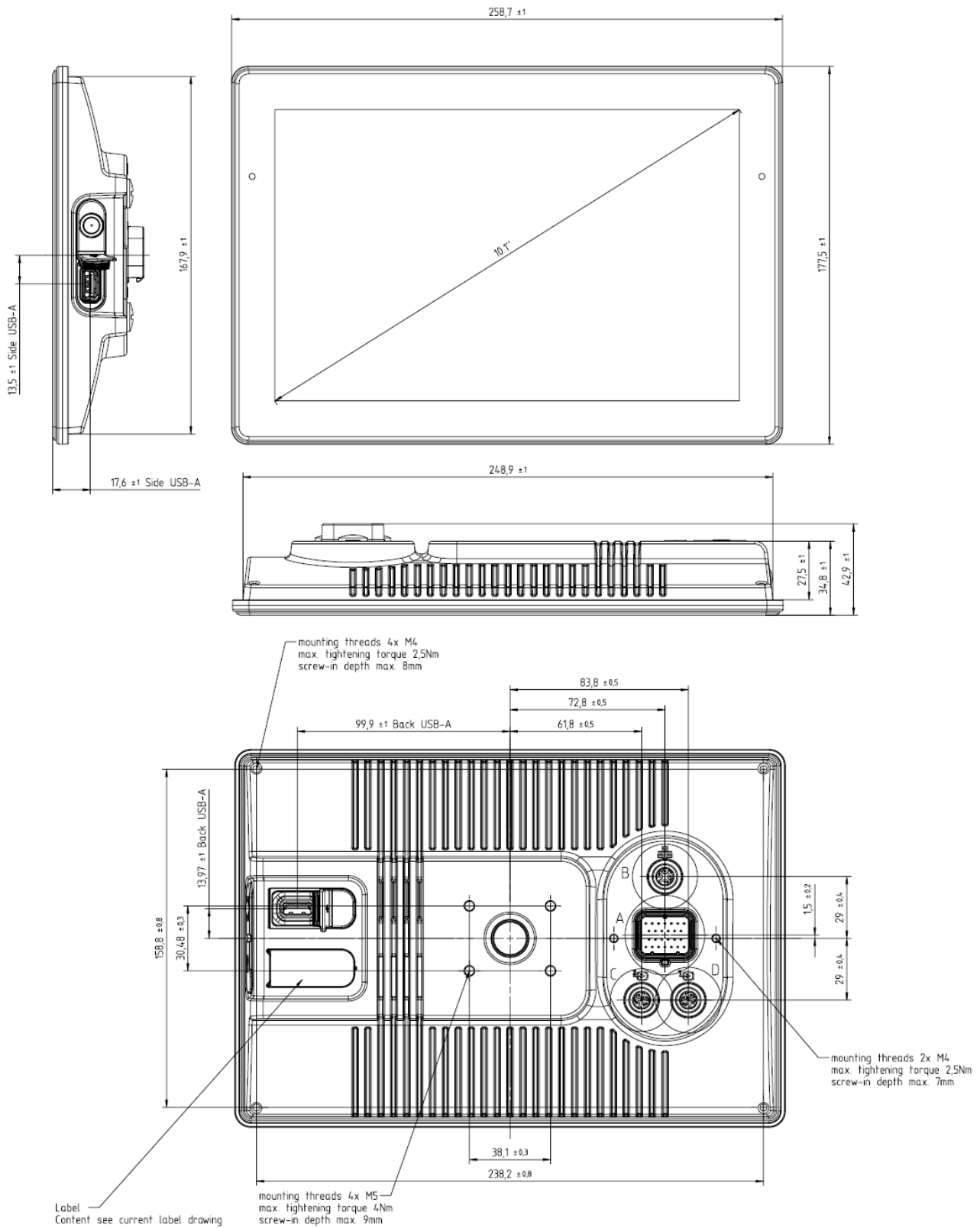

6.2 Specification

	OPUS B6 ECO	
	Basic	Full
Dashboard Mount	X	X
Dimensions (mm)	H178x W260 x D48	H178x W260 x D48
Display size	1280x800 pixels	1280x800 pixels
Touchscreen	X	X
Optical Signal	1	1
Speaker	X	X
Processor Speed	800 MHz I.MX6	1000 MHz, I.MX6
RAM	1 GB DDR3	2 GB DDR3
Mass Storage	4 GB	8 GB
EEPROM	1 kB serial	1 kB serial
CAN bus	4	4
RS232	1	1
USB 2.0 full speed	2	2
Ethernet	X (IE)	X
Video in	2	2
Real time clock	X	X
Light Sensor	X	X
Audio Out	X	X

6.3 Declaration of Conformity



EU-Konformitätserklärung EU Declaration of Conformity

für die Produktfamilie: **OPUS B6 Eco Full**
for the product family:

bestehend aus folgenden Modellen:
consisting of the following models:
OPUSB6EN1CANB000, OPUSB6EN1CANF000, OPUSB6EN1CANA000,
OPUSB6EN1CDSB000, OPUSB6EN1CDSF000, OPUSB6EN1CDSA000,
OPUSB6EN1CWF000, OPUSB6EN1CWF000, OPUSB6EN1CANBK48,
OPUSB6EN1CANBC85, OPUSB6EN1CDSBC85

Für die oben bezeichnete Produktfamilie wird hiermit erklärt, dass diese den wesentlichen Schutzanforderungen entspricht, die in den nachfolgend bezeichneten Richtlinien festgelegt sind:
The indicated product family is in conformance with the regulations of the following European Directives:

- **2014/30/EU (EMV-Richtlinie)**
RICHTLINIE 2014/30/EU DES EUROPÄISCHEN PARLAMENTS UND DES RATES vom 26. Februar 2014 zur Harmonisierung der Rechtsvorschriften der Mitgliedstaaten über die elektromagnetische Verträglichkeit
DIRECTIVE 2014/30/EU OF THE EUROPEAN PARLIAMENT AND OF THE COUNCIL of 26 February 2014 on the harmonisation of the laws of the Member States relating to electromagnetic compatibility
 - Die Konformität wird in Bezug auf folgende angewandte harmonisierte Europäische Normen erklärt:
Conformity is declared with reference to the following harmonized European standards:
 - EN ISO 13766-1 2019 EMV Baumaschinen
 - EN ISO 14982 2009 EMV Land- u. Forstwirtschaftliche Masch.
 - EN 50498 2011 Altermarkt electronic equip. in vehicles
 - EN 61000-6-4 2011 EMV Industriebereiche u Fachgrundnorm
 - EN 61000-6-2 2019 EMV Industriebereiche u Fachgrundnorm
- **2011/65/EU (RoHS-Richtlinie)**
RICHTLINIE 2011/65/EU DES EUROPÄISCHEN PARLAMENTS UND DES RATES vom 8. Juni 2011 zur Beschränkung der Verwendung bestimmter gefährlicher Stoffe in Elektro- und Elektronikgeräten
DIRECTIVE 2011/65/EU OF THE EUROPEAN PARLIAMENT AND OF THE COUNCIL of 8 June 2011 on the restriction of the use of certain hazardous substances in electrical and electronic equipment
- **2015/863/EU (RoHS-Richtlinie Änderung)**
DELEGIERTE RICHTLINIE (EU) 2015/863 DER KOMMISSION zur Änderung von Anhang II der Richtlinie 2011/65/EU des Europäischen Parlaments und des Rates hinsichtlich der Liste der Stoffe, die Beschränkungen unterliegen
COMMISSION DELEGATED DIRECTIVE (EU) 2015/863 amending Annex II to Directive 2011/65/EU of the European Parliament and of the Council as regards the list of restricted substances

Topcon Electronics GmbH & Co KG
Industrieallee 7 | D-63306 Gießenheim | Germany
Telefon: +49 (0) 6722 4028 0
Telefax: +49 (0) 6722 4028 850
www.topcon-electronics.com

Antigenricht Weibaden HRB 7411 | Ust-ID-Nr. DE 113927257 | Steuer-Nr. 26 037 379 00025
Kontingenteile: Topcon ME GmbH | Geschäftsbereich: Abent Zentrale
Rheinischer Volksbank | Gießenheim | IBAN DE 56 21021500 0000 69699 | BIC: GENO DE 51 850
Rheinische Post Bank (BHW-Gruppe) | Mainz | IBAN DE 19 00000101 000200717 | BIC: ROLA DE33
Deutsche Bank | Weibaden | IBAN DE 45 51020121 0000 00000 | BIC: DEUT DE 33 010
General Terms and conditions (GTC) are available here: www.topcon-electronics.com



- **2017/2102/EU (RoHS-Richtlinie Änderung)**
RICHTLINIE (EU) 2017/2102 DES EUROPÄISCHEN PARLAMENTS UND DES RATES vom 15. November 2017 zur Änderung der Richtlinie 2011/65/EU zur Beschränkung der Verwendung bestimmter gefährlicher Stoffe in Elektro- und Elektronikgeräten
DIRECTIVE (EU) 2017/2102 OF THE EUROPEAN PARLIAMENT AND OF THE COUNCIL of 15 November 2017 amending Directive 2011/65/EU on the restriction of the use of certain hazardous substances in electrical and electronic equipment

Dipl.-Ing. (FH) Torsten Volk, Project Manager
Titel, Name, Position, Unterschrift / Name, Title, Position, Signature  01.02.2023
Datum / Date

Dipl.-Wirtsch.-Ing. (FH) Thilo Nagel, General Manager
Titel, Name, Position, Unterschrift / Name, Title, Position, Signature  01.02.2023
Datum / Date

Topcon Electronics GmbH & Co KG
Industrieallee 7 | D-63306 Gießenheim | Germany
Telefon: +49 (0) 6722 4028 0
Telefax: +49 (0) 6722 4028 850
www.topcon-electronics.com

Antigenricht Weibaden HRB 7411 | Ust-ID-Nr. DE 113927257 | Steuer-Nr. 26 037 379 00025
Kontingenteile: Topcon ME GmbH | Geschäftsbereich: Abent Zentrale
Rheinischer Volksbank | Gießenheim | IBAN DE 56 21021500 0000 69699 | BIC: GENO DE 51 850
Rheinische Post Bank (BHW-Gruppe) | Mainz | IBAN DE 19 00000101 000200717 | BIC: ROLA DE33
Deutsche Bank | Weibaden | IBAN DE 45 51020121 0000 00000 | BIC: DEUT DE 33 010
General Terms and conditions (GTC) are available here: www.topcon-electronics.com

**LAST PAGE IS FOR INTERNAL USE ONLY!
NOT TO BE USED WITHIN OFFICIAL RELEASES!**

Revision

Revision	Date	Author	Comment
0.1	27.01.2023	TV	First release
0.2	01.02.2023	KW	CE conformity
0.3	03.05.2023	KW	Add image for CAN termination
0.6	15.05.2023	TV	Review
1.0	26.05.2023	KW	Freigabe
1.1	16.02.2024	CST	Company name changed, ISO information added, some cleanup
2.0	23.02.2024	CST	Unification of pages, more ISO information added
2.1	04.11.2025	SHV	More information for Wake Input added
3.0	21.11.2025	MLR	Silicon cover removed, added burn-in warning

Approval

Dokumenten-Name	OPUS B6 Operating Manual Hardware Description
Status:	Serie
Datum:	01.02.2023
Sharepoint – Revision:	2.0
Datum dieser Revision	26.02.2024
Erstellt:	CST
Geprüft:	CST
Freigegeben:	CST, 26.02.2024